PFANKUCH Feeder Head

Model ASB175-/310-/380-/450-KHS

High-Speed Servomotor Equipment with Horizontal Delivery

Automatic separating, counting and feeding of flat products with highest cycle speeds

Machine Concept

In comparison to the standard version of PFANKUCH ASB feeder heads, the „HS“-version is equipped with up to date servomotor technique and offers extended possibilities for special machine applications. The High-Speed HS-version is recommended for application areas with demands for highest cycle speeds. Special servomotor technique and control engineering allows feeding speeds up to 220 m / minute and cycle speeds up to 800 products per minute (start / stop modus depending on product specifications).

Apart from the special servomotor and controlling equipment the HS-machine concept is based on the field proven and matured PFANKUCH ASB feeder head technique. ASB feeder heads operate on a top load bottom feed friction principle. Flexible, profiled and anti static feed belts separate the lowest product damage-free from the magazine pile into a standby position for a photo optical double and miss-feed control. Out of this position, the cycled feeding process is initiated by an electronic start sensor. Contra rotating stripper wheels prevent simultaneous feeding of following products. The available variety of PFANKUCH ASB models offers different feeder width dimensions for processing product sizes up to 370 mm width (see technical data). The modular technical design also considers multiple possibilities for most exact product positioning according to customer demands. Furthermore the design allows easy and uncomplicated machine integration into existing customer machinery.

The horizontal delivery is height adjustable and helps to bridge the gap between feeder and product dispensing position in horizontal direction. There are different lengths (245, 505 and 620 mm) available .

Technical Machine Equipment HS-version

- Variable speed adjustability from 0 up to 220 m/min.
- Highest cycle speeds up to 800 products / min. (depending on specifications)
- External electronic control cabinet (500 x 500 mm)

Advantages at a Glance

- Innovative microprocessor control and servomotor technique for highest feeder and cycle speeds
- Highest cycle speeds and reliable operation security ensure most efficient productivity, efficiency and profitability
- Secure and damage-free product separation and feeding – even for most sensitive products
- Modular machine design offers various choices for meeting specific customer demands in technical machine layout
- Easy and uncomplicated machine integration

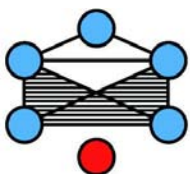
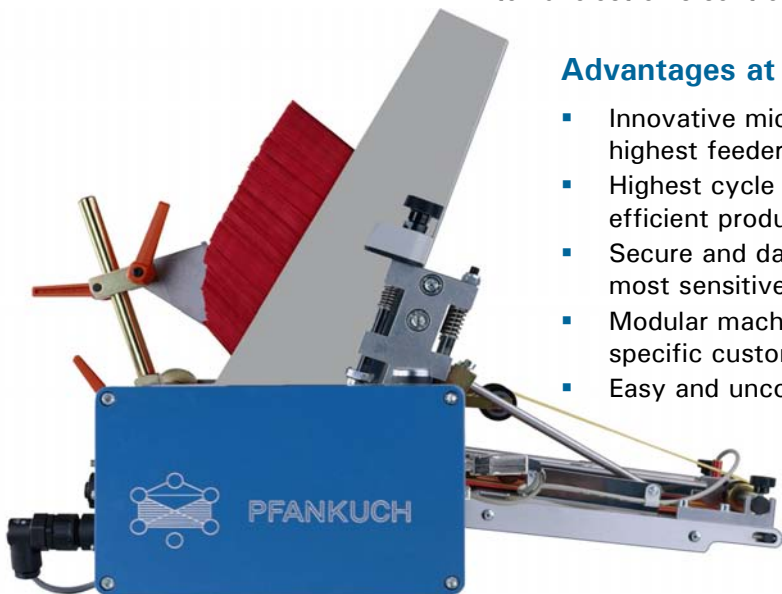

PFANKUCH

PFANKUCH MASCHINEN GMBH
Kurt-Fischer-Str. 23b
D – 22926 Ahrensburg / Germany
Tel. +49 (0) 4102-47810
Fax +49 (0) 4102-478180
www.pfankuch.com
info@pfankuch.com

Technical Data

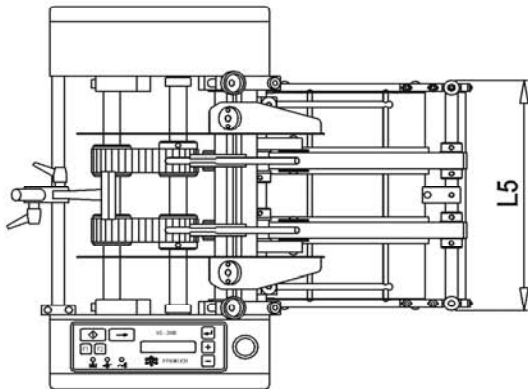
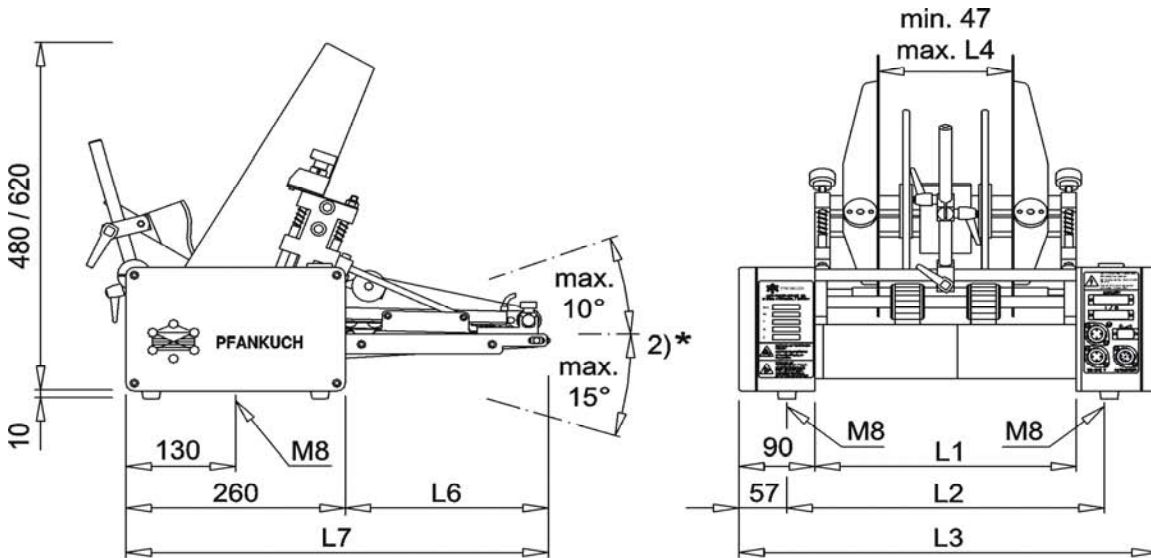

PRODUCTION
FLOW

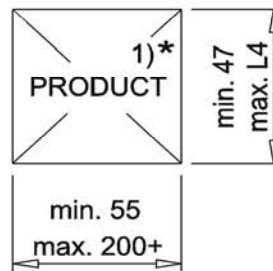

ASB -K -HS/ -HSP
CONTROL UNIT RIGHT

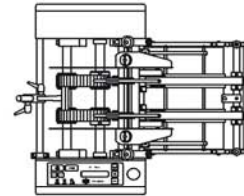

ASB -KR -HS/ -HSP
CONTROL UNIT LEFT

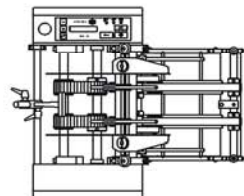

- 1)* Other dimensions possible on request
2)* Other angle of inclination possible on request

Feeder Model	L1 (mm)	L2 (mm)	L3 (mm)	L4 (mm)	L5 (mm)	Max. Speed (depending on product specs.)	Weight (net Kg)
ASB 175-K-HS/ -HSP	175	241	361	95	165	220 m/min.	24
ASB 310-K-HS/ -HSP	310	376	496	230	300	220 m/min.	29
ASB 380-K-HS/ -HSP	380	446	566	300	370	220 m/min.	36
ASB 450-K-HS/ -HSP	450	516	636	370	440	220 m/min.	43

Horizontal Delivery	L6 (mm)	L7 (mm)
Type 150	245	505
Type 380	505	765
Type 500	620	880

Multi Voltage : 110 / 230 V, 50-60 HZ, 1 KW
Drive : Servo Motor
Protective System : Standard: IP43 (Special Option: IP 63)
Separate Control Cabinet : 500 x 500 x 200 mm

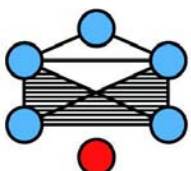

PFANKUCH

PFANKUCH MASCHINEN GMBH
Kurt-Fischer-Str. 23b
D – 22926 Ahrensburg / Germany
Tel. +49 (0) 4102-47810
Fax +49 (0) 4102-478180
www.pfankuch.com
info@pfankuch.com