

# PFANKUCH ASB SHEET FEEDER

## SERIES 310-K / 380-K / 450-K WITH INVERTED DELIVERY

Top load bottom feed is the efficient design of all PFANKUCH feeder heads. The side-guided magazine holds up to a 20" stack of product. The material pile leans slightly forward towards a shaped front guide to ensure minimum pressure on the bottom sheet. The PFANKUCH shaped back rest helps the products to slide gently into the feed position under the unique PFANKUCH contra rotating stripper wheels. Profiled anti static feed belts separate the lowest piece of the pile and bring it damage free into the standby position for feeding into the production run. The self adjusting, photo optical double and mis feed control surveys the flawless function.

The feed signal for the product comes from an electronic start sensor. The product is ejected from a pre-checked standby position. This limits the feed action to a fraction of a second.

All PFANKUCH feeder functions are controlled by the Touch Panel of the PFANKUCH VS-2000 Dialog-Processor. Peripheral functions such as PFANKUCH AUTOLOADERS are powered and guided by the unique PFANKUCH compact control system.

The **ASB WITH INVERTED DELIVERY** turns the piece to be fed 180° prior to ejecting into the production process. This applies when the product stack is sequentially face down and has to be fed into the process face up.

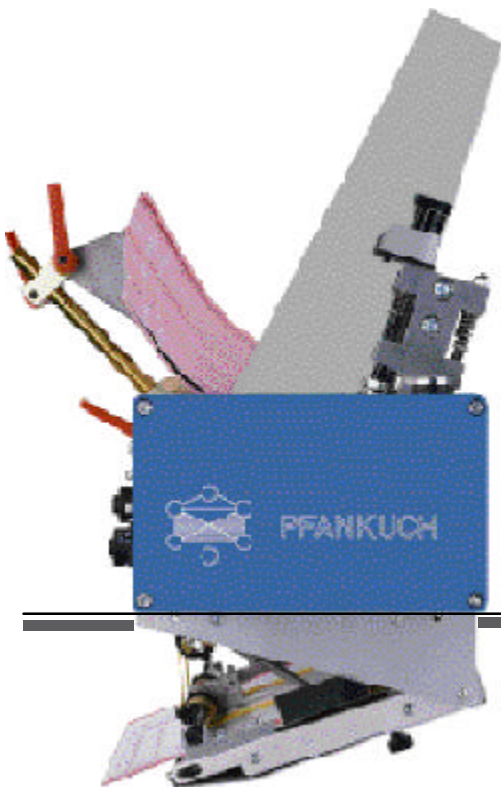

PFANKUCH MASCHINEN GMBH  
KURT-FISCHER-STRASSE 23 b  
GERMANY 22926 AHRENSBURG  
TEL. + 49 (0) 4102 - 4781-0  
FAX + 49 (0) 4102 - 478180  
INFO@PFANKUCH.COM  
WWW.PFANKUCH.COM

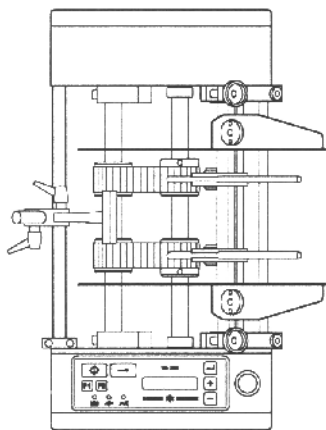
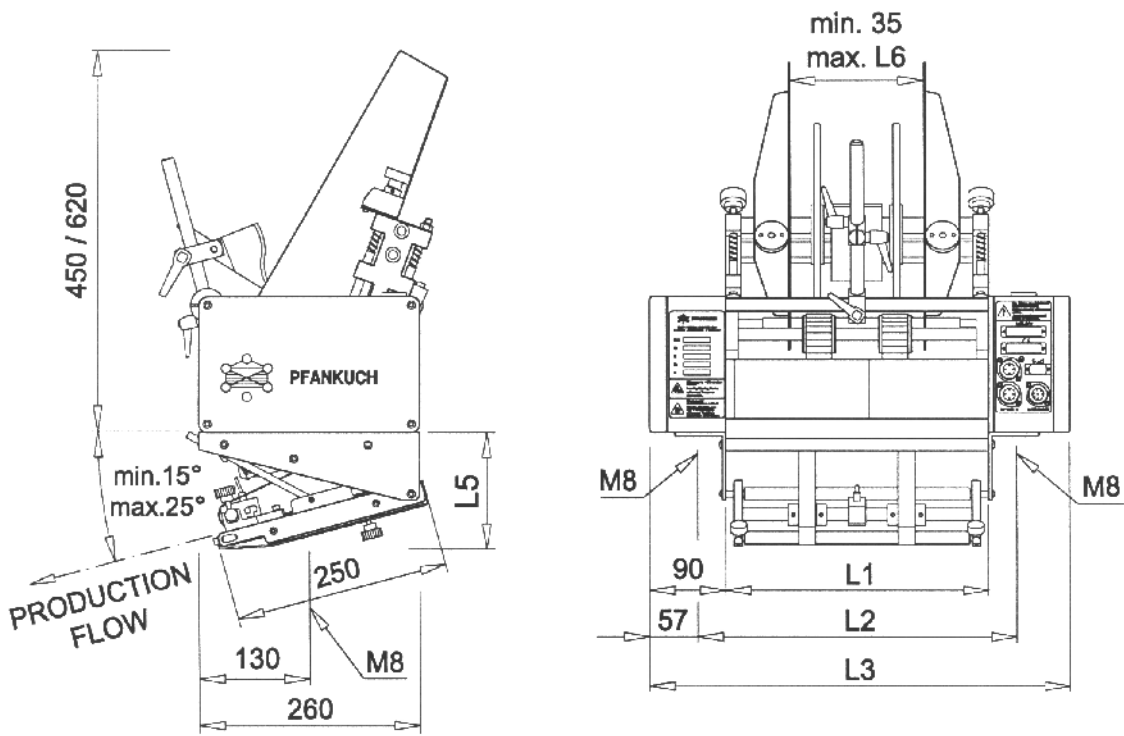

PRODUCTION

FLOW

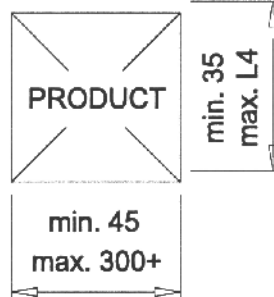

ASB -K  
CONTROL UNIT RIGHT

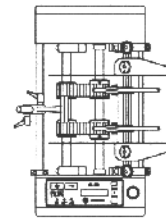

ASB -KR  
CONTROL UNIT LEFT

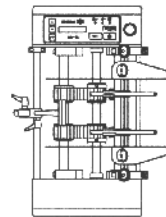

## TECHNICAL DATA

FEEDER	L1 [mm]	L2 [mm]	L3 [mm]	L4 [mm]	L5 [mm]		OUTPUT max.	WEIGHT [net Kg]
					min.	max.		
ASB 310-K / -KR	310	376	496	250	140	180	115 m/min.	31
ASB 380-K / -KR	380	446	566	320			115 m/min.	35

VOLTAGE : 90 - 240 V · 50 - 400 Hz · 0,4 KW

DRIVE : Servo motor

PROTECTION CLASS : standard IP 43 · special IP 64



**PFANKUCH**

PFANKUCH MASCHINEN GMBH  
KURT-FISCHER-STRASSE 23 b  
GERMANY 22926 AHRENSBURG  
TEL. + 49 (0) 4102 - 4781 - 0  
FAX + 49 (0) 4102 - 478180  
INFO@PFANKUCH.COM  
WWW.PFANKUCH.COM